



#1 SELLING TRANSLOADER IN NORTH AMERICA



“THE SCORPION  
3015 TRANSLOADER  
HAS GIVEN US THE  
EDGE OVER THE  
COMPETITION”  
- 2019 CUSTOMER



WWW.CAMBELT.COM



# THE CAMBELT SCORPION® 3015

## TRANSLOADER DIFFERENTIATING FEATURES



CAMBELT'S UNIQUE CONVEYOR SYSTEM with minimal footprint (just 27' inlet to discharge), the Scorpion Transloader 3015 sports world class power: 8500CF/Hr @800FRM

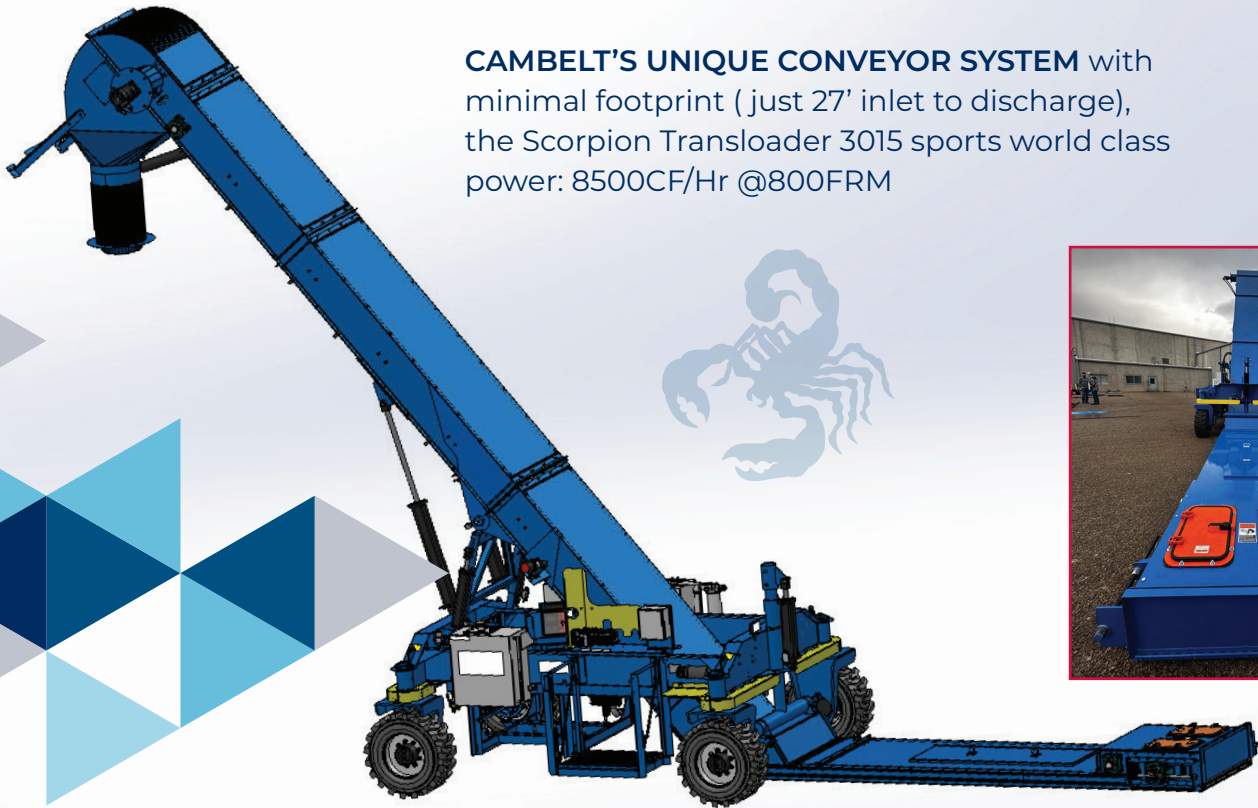

**#1 The Eliminator Take-Up** (patent pending)

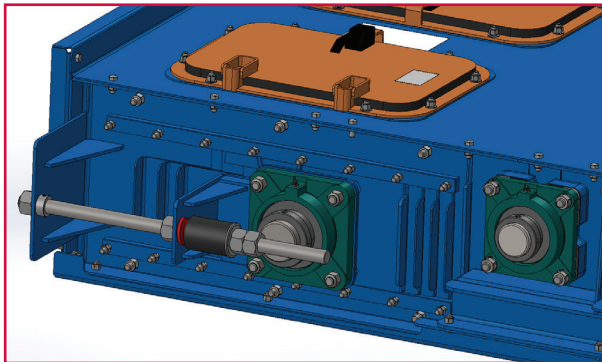

**#2 The Proprietary Bearings** (patent pending)

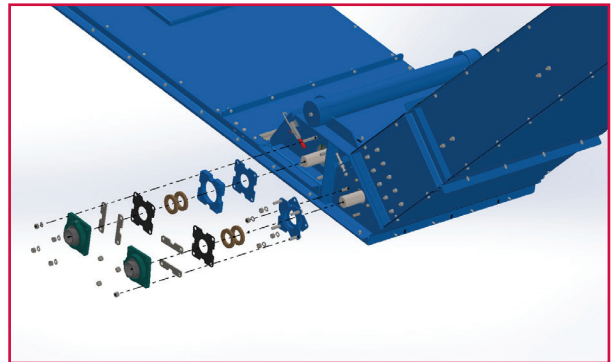

**#3 The Cambelt Control Cockpit**

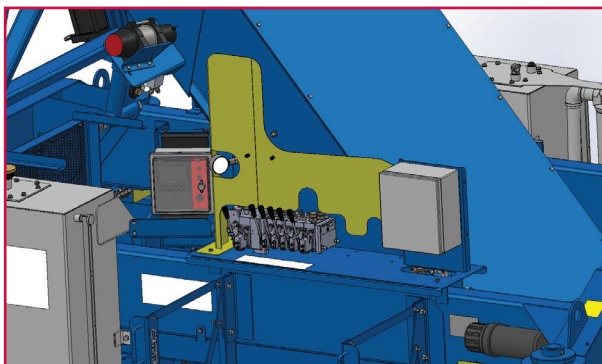

**#4 The Cambelt Belt System**

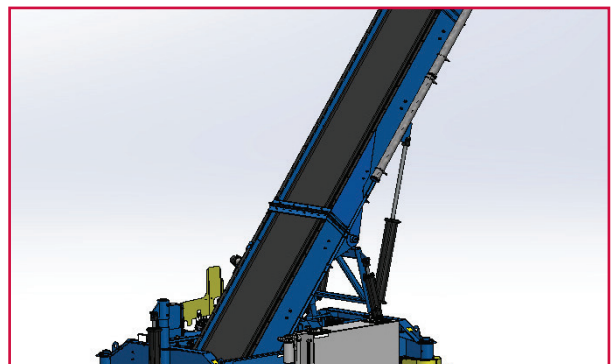



## #1 THE ELIMINATOR TAKE-UP

- The Eliminator take-up is truly unique as it keeps the bearings away from debris and damage from the material being moved by the conveyor. No other transloader on the market has this feature!

## #2 THE PROPRIETARY BEARING SEALS

(patent pending)

- Separated from housing by a seal chamber between the housing and the bearing.
- Spacer bars create a gap between the seal chamber and the bearing (cooling and product drop point).
- Notches under the bearing for easy removal with a puller means no pry bar damage.
- Bearing life has been extended with minimal maintenance.

## #3 THE CAMBELT CONTROL COCKPIT

- Engine controls are conveniently located while standing on the operators platform.
- Easy to operate, minimal control allow anyone to operate with ease.
- Independent front and rear steering for pinpoint maneuvering in tight spaces.
- 180° Steering with front and rear drives for easy adjustments while relocating from rail hopper to hopper.

## #4 THE CAMBELT : ULTIMATE IN SPEED & POWER

- CF3015 Belt is the GOLD STANDARD. It conveys fine to granular materials with Best in Class Speed & efficiency.
- CF3015 Belt has *Best in Class* Durability.
- CF3015 generates a constant flow with *Best in Class*. Steep Incline Performance.
- CF3015 Boasts ZERO Delamination.

**“The Eliminator Take-Up makes maintenance easy and has extended the life of our bearings.”**

- TX Customer, 2024

**“These Bearings lasted 5X longer than the others!”**

- TX Customer, 2024

**“My guys have total control, super easy to drive and they can see everything from the cockpit”**

- UT Customer, 2019

**“We move entire traincar loads in only 10 minutes”**

- TX Customer, 2023

# THE CAMBELT 1210 TRANSLOADER



## SCORPION 1210 TRANSLOADER KEY FEATURES:

- Clearance capable of center loading  
16' 1" Railcar
- Convenient electricity powered
- Dust collection "quick connect" (option for 2024)
- Manually controlled snorkel
- Short lead time
- Emergency spare parts



Watch the Scorpion 1210 Transloader in action here!

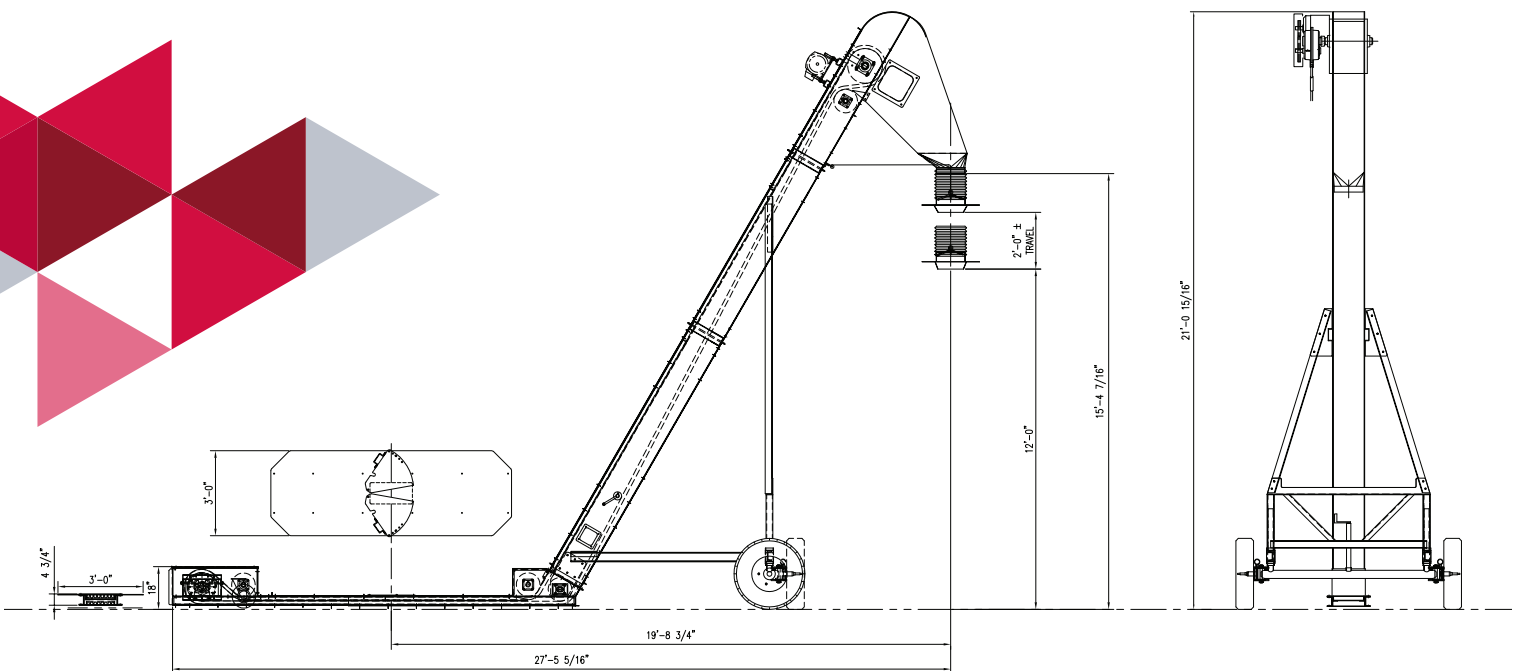

## CAMWALL



No other Belt can match the Superior design and World Class Performance

- Up to 90° incline Capability

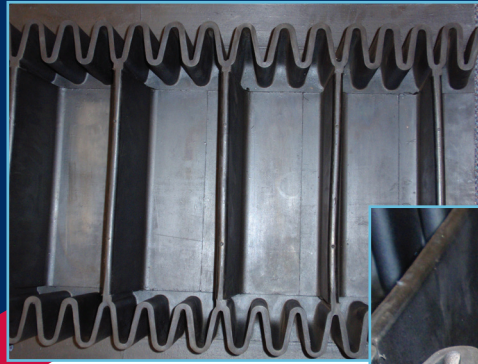

## CAMBELT

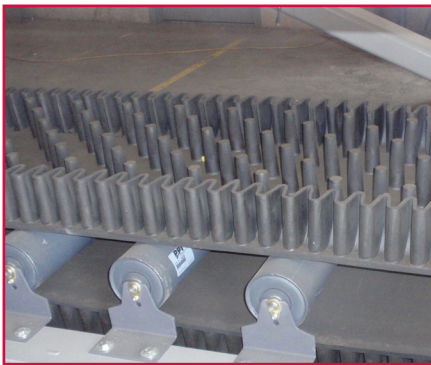

The **GOLD STANDARD** in High Incline Conveyor Belts

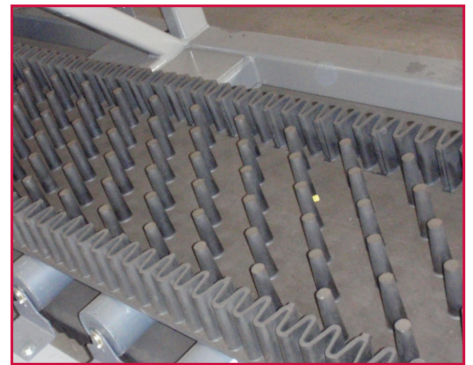

## CAMFLEX

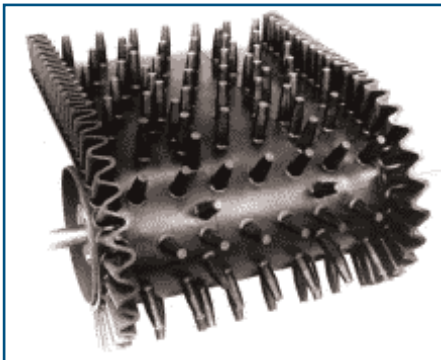

**65° - 70° Inclines!**  
No other belt can match the performance and durability

# THE CAMBELT SCORPION® 3015 TRANSLOADER SPECS



- Hydraulics to lift conveyor into position once on site - NO LIFTING!
- Easy set-up, connect belt & drive off ability
- Dust Collection "quick connect"
- Dump Hopper on Slimline includes outriggers for support
- Easy access maintenance

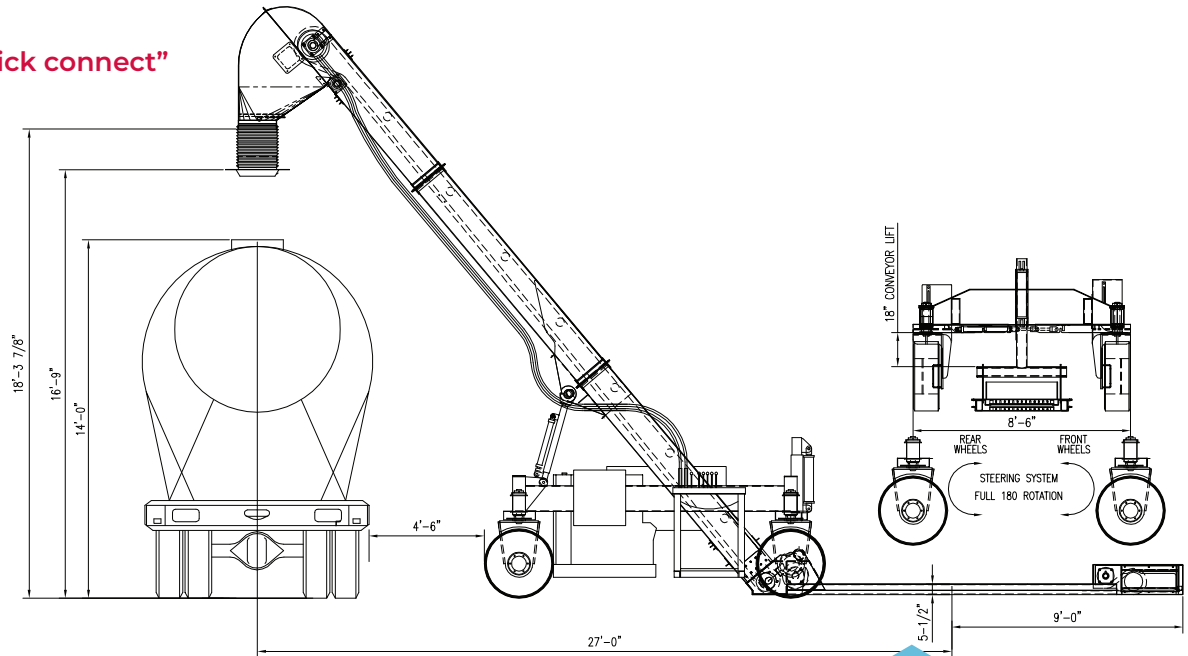

**2024 MODELS IN STOCK | CONTACT CAMBELT SALES TODAY!**

**Just 27' from Inlet to Discharge - That's BEST IN CLASS (18' smaller than next competitor)**

1. Provides 16' of loading clearance, stretching to over 18' with snorkel removed
2. Just 8' 6" wide, *Best in Class*
3. Tier 4 Engine, 2 wheel drive with 4 wheel steering
4. 18" Hydraulic lift for easy use on uneven surfaces
5. Front & Rear Wheels rotate 180° for ultimate maneuverability

**"Our business took off last year when we bought the 3015. We went from 1 truckload every 40 minutes with the (competitor) to 1 every 10 minutes. That's 4 times faster! DO THE MATH! We won't ever buy the (competitor again)" - Customer 2023**



**Watch the Scorpion 3015 Transloader in ACTION here!**